



ARISTAIPC

Waterproof Touch Screen Monitors

Datasheet Collection

www.aristaipc.com

Contents

Industrial Displays

Waterproof Touch Screen Monitors

ADM-2121AX	03
ADM-5815AX	05
ADM-5817AX	07
ADM-5819AX	09
ADM-5842AX	11



ADM-2121AX

Waterproof 21.5-inch KVM Extender Integrated LCD Display Monitor

Features

- 21.5-inch LCD Display, 1920 x 1080 resolutions
- Project Capacitive Touch Screen supports multi-touch
- Waterproof Stainless-Steel Enclosure
- Enclosure meets IP65 / NEMA 4X requirements
- Single CAT6 cable connection to KVM Transmitter
- Powered by Transmitter
- Built-in a 2-port USB 2.0 hub to support multiple USB devices.
- Built-in a 1-port 100BaseT Ethernet pass-through

Specifications

Model Name	ADM-2121AX
LCD Display	
Display Size	21.5"
Max Resolution	1920 x 1080
Backlight Lifetime	50,000 hours
Visual Characteristics	
Colors	16.7 million
Aspect Ratio	16:9
Viewing Angle (V/H)	178° / 178°
Contrast Ratio	1000:1
Brightness	250 nits
Input Interface	
VGA	N/A
DVI	N/A
HDMI	Via HDMI Transmitter
Display Port	N/A
CVBS	N/A
YPbPr	N/A
Touchscreen	
Technology	Projected Capacitive
Interface	USB
Driver	Win 7, Win10
Enclosure	
Enclosure	Stainless Steel
Protection	Meets NEMA 4X
Power/Thermal Specs	
Power Requirement (Max)	Powered By HDMI Transmitter
Power Consumption (Max)	23 W
Recommended Power Supply	32 W
Heat Dissipation	77 BTU/hr
Physical Information	
Mounting	Pedestal, VESA, Wall mount, Benchtop Options
Net Weight	--
Dimension (W x H x D)	21.15 x 12.98 x 3.69 inch 537.2 x 329.8 x 93.7 mm
Recommended Cutout Dimension (WxH)	N/A
Rating	Meets NEMA 4X
Certification	N/A
Environmental	
Operating Temperature	0°C to 50°C (32°F to 122°F)
Storage Temperature	-20°C to 60°C (-4°F to 140°F)
Humidity	5% to 95% non-condensing

Dimension Drawing

Model Name: ADM-2121AX
 Size Unit: inch(mm)

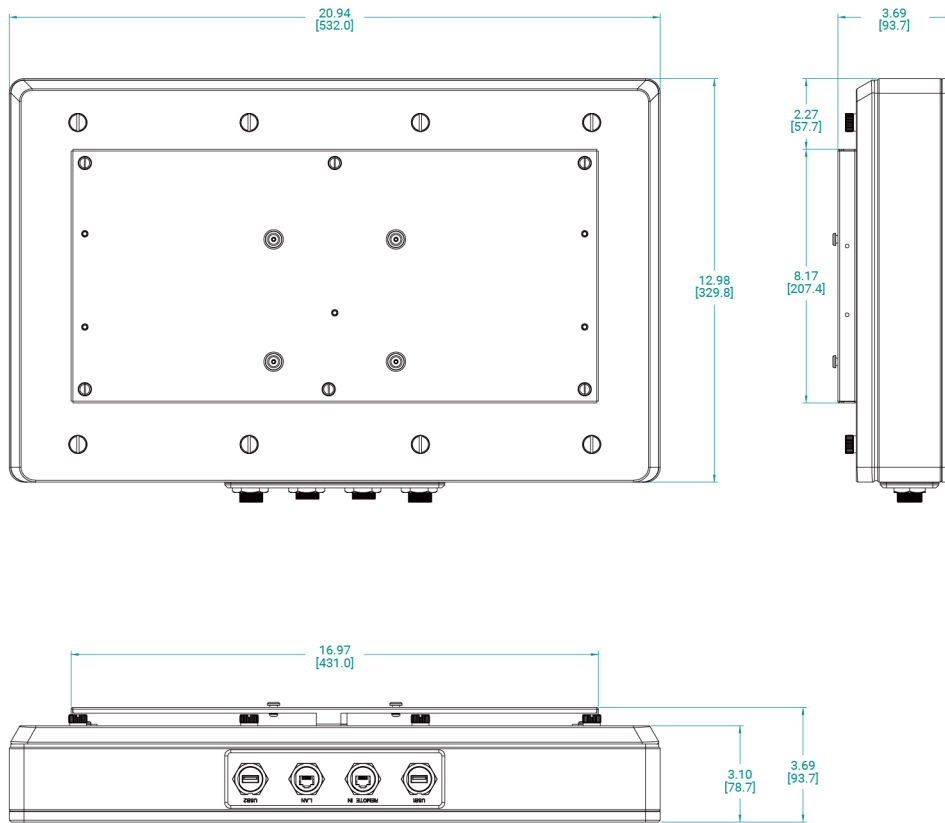

Ordering Information

Item	ADM-2121AX-00A
LCD Display	21.5" LCD / 1920 x 1080
Touch Screen	PCAP
Mounting	Multiple Options
Enclosure	Stainless Steel
Extender Video Input	HDMI via HDMI Transmitter
Power Supply	Powered by HDMI Transmitter



ADM-5815AX

Waterproof 15-inch KVM Extender Integrated LCD Display Monitor

Features

- 15-inch LCD Display, 1024 x 768 resolutions
- 5-Wire Resistive Touch Screen
- Waterproof Stainless-Steel Enclosure
- Enclosure meets IP65 / NEMA 4X requirements

Integrated HDMI & USB Extender Option:

- Single CAT6 cable connection to KVM Transmitter
- True one-cable solution up to 100 meters CAT6 cable, no power supply is required
- Powered by Transmitter
- Built-in a 2-port USB 2.0 hub to support multiple USB devices.
- Built-in a 1-port 100BaseT Ethernet pass-through

Integrated VGA & RS-232 Extender Option:

- Video signal transmission length up to 1,000 ft (330m) over CAT5e cable
- Adjustable equalization and gain control
- De-skew compensation available for RGB delay control
- 24VDC Input

Specifications

Model Name	ADM-5815AX
LCD Display	
Display Size	15"
Max Resolution	1024 x 768
Backlight Lifetime	50,000 hours
Visual Characteristics	
Colors	16.7 million
Aspect Ratio	5:4
Viewing Angle (V/H)	140° / 160°
Contrast Ratio	700:1
Brightness	300 nits
Input Interface	
VGA	Via VGA Transmitter
DVI	N/A
HDMI	Via HDMI Transmitter
Display Port	N/A
CVBS	N/A
YPbPr	N/A
Touchscreen	
Technology	5-Wire Resistive
Interface	RS-232 Via VGA Transmitter / USB Via HDMI Transmitter
Driver	Win XP, Win 7, Win10
Enclosure	
Color	Stainless Steel
Protection	Meets NEMA 4X
Power/Thermal Specs	
Power Requirement (Max)	24VDC / 0.44A
Power Consumption (Max)	11 W
Recommended Power Supply	15 W
Heat Dissipation	36 BTU/hr
Physical Information	
Mounting	Multiple Mount Options
Net Weight	27 Lbs/ 12.24 kg
Dimension (W x H x D)	14.51 x 12.42 x 4.09 inch 368.6 x 315.5 x 103.9 mm
Recommended Cutout Dimension (WxH)	N/A
Rating	Meets NEMA 4X
Certification	UL508
Environmental	
Operating Temperature	0 to 50°C (32 to 122°F)
Storage Temperature	-20 to 60°C (-4 to 140°F)
Humidity	5% to 95% non-condensing

Dimension Drawing

Model Name: ADM-5815AX
Size Unit: inch(mm)

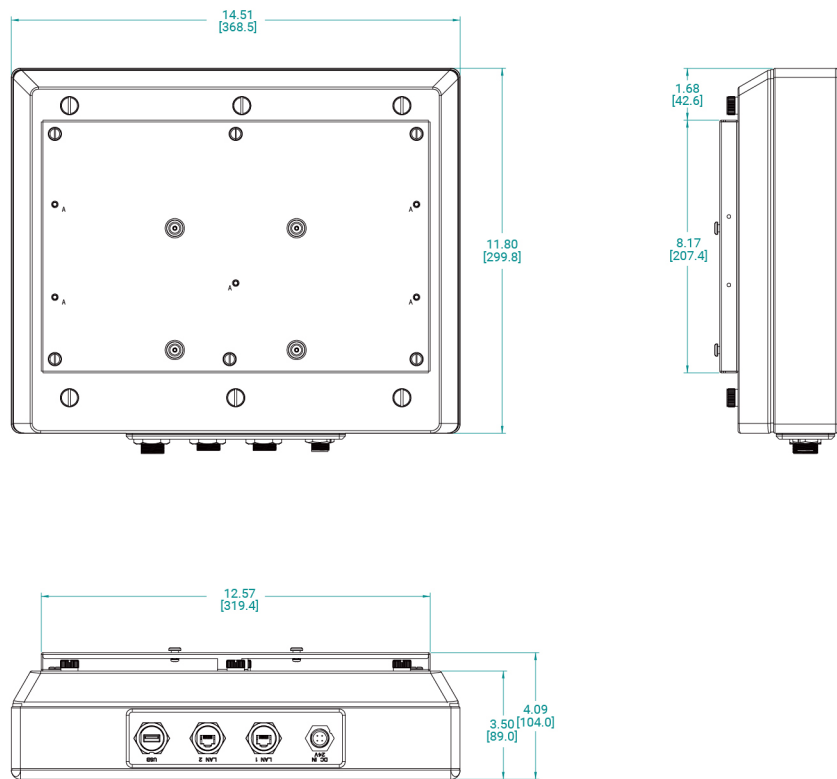

Ordering Information

Item	ADM-5815AX-00A
LCD Display	15" / 1024 x 768
Touch Screen	5-Wire Resistive
Enclosure	Stainless Steel
Extender Video Input	HDMI via HDMI Transmitter
Power Supply	Powered by HDMI Transmitter



ADM-5817AX

Waterproof 17-inch KVM Extender Integrated LCD Display Monitor

Features

- 17-inch LCD Display, 1280 x 1024 resolutions
- 5-Wire Resistive Touch Screen
- Waterproof Stainless-Steel Enclosure
- Enclosure meets IP65 / NEMA 4X requirements

Integrated HDMI & USB Extender Option:

- Single CAT6 cable connection to KVM Transmitter
- True one-cable solution up to 100 meters CAT6 cable, no power supply is required
- Powered by Transmitter
- Built-in a 2-port USB 2.0 hub to support multiple USB devices.
- Built-in a 1-port 100BaseT Ethernet pass-through

Integrated VGA & RS-232 Extender Option:

- Video signal transmission length up to 1,000 ft (330m) over CAT5e cable
- Adjustable equalization and gain control
- De-skew compensation available for RGB delay control
- 24VDC Input

Specifications

Model Name	ADM-5817AX
LCD Display	
Display Size	17"
Max Resolution	1280 x 1024
Backlight Lifetime	50,000 hours
Visual Characteristics	
Colors	16.7 million
Aspect Ratio	5:4
Viewing Angle (V/H)	140° / 160°
Contrast Ratio	800:1
Brightness	350 nits
Input Interface	
VGA	Via VGA Transmitter
DVI	N/A
HDMI	Via HDMI Transmitter
Display Port	N/A
CVBS	N/A
YPbPr	N/A
Touchscreen	
Technology	5-Wire Resistive
Interface	RS-232 Via VGA Transmitter / USB Via HDMI Transmitter
Driver	Win XP, Win 7, Win10
Enclosure	
Color	Stainless Steel
Protection	Meets NEMA 4X
Power/Thermal Specs	
Power Requirement (Max)	24VDC / 0.53A
Power Consumption (Max)	13 W
Recommended Power Supply	18 W
Heat Dissipation	43 BTU/hr
Physical Information	
Mounting	Multiple Mount Options
Net Weight	29 Lbs / 13.15 Kg
Dimension (W x H x D)	15.88 x 14.07 x 4.36 inch 403.4 x 357.4 x 110.7 mm
Recommended Cutout Dimension (WxH)	N/A
Rating	Meets NEMA 4X
Certification	UL508
Environmental	
Operating Temperature	0 to 50°C (32 to 122°F)
Storage Temperature	-20 to 60°C (-4 to 140°F)
Humidity	5% to 95% non-condensing

Dimension Drawing

Model Name: ADM-5817AX
 Size Unit: inch(mm)

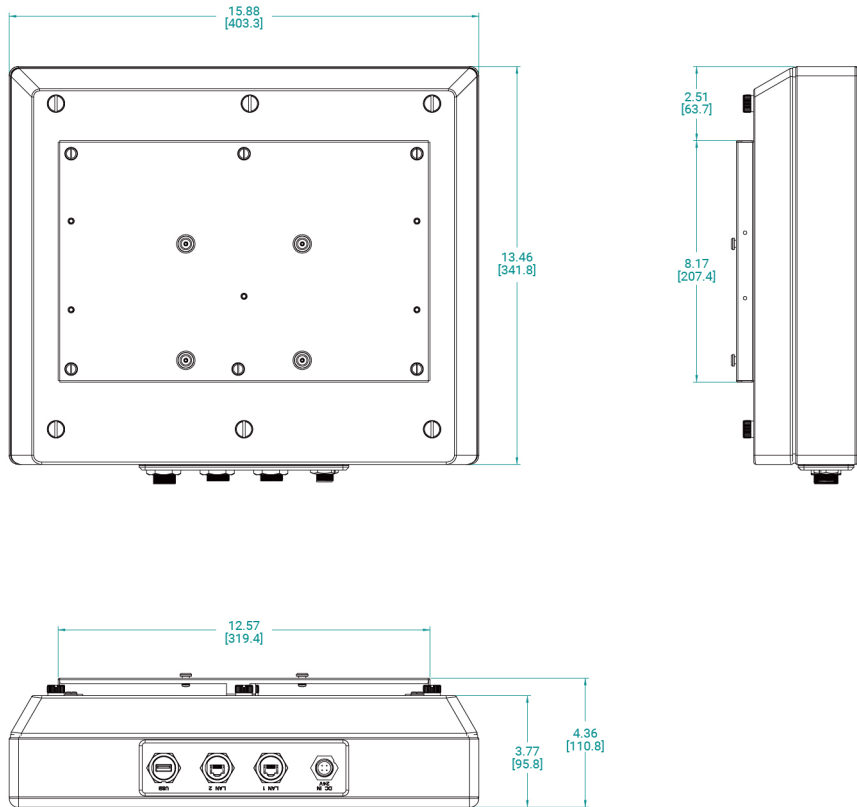

Ordering Information

Item	ADM-5817AX-00A
LCD Display	17" / 1280 x 1024
Touch Screen	5-Wire Resistive
Enclosure	Stainless Steel
Extender Video Input	HDMI via HDMI Transmitter
Power Supply	Powered by HDMI Transmitter



Integrated VGA & RS-232 Extender Option:

- Video signal transmission length up to 1,000 ft (330m) over CAT5e cable
- Adjustable equalization and gain control
- De-skew compensation available for RGB delay control
- 24VDC Input

ADM-5819AX

Waterproof 19-inch KVM Extender Integrated LCD Display Monitor

Features

- 19-inch LCD Display, 1280 x 1024 resolutions
- 5-Wire Resistive Touch Screen
- Waterproof Stainless-Steel Enclosure
- Enclosure meets IP65 / NEMA 4X requirements

Integrated HDMI & USB Extender Option:

- Single CAT6 cable connection to KVM Transmitter
- True one-cable solution up to 100 meters CAT6 cable, no power supply is required
- Powered by Transmitter
- Built-in a 2-port USB 2.0 hub to support multiple USB devices.
- Built-in a 1-port 100BaseT Ethernet pass-through

Specifications

Model Name	ADM-5819AX
LCD Display	
Display Size	19"
Max Resolution	1280 x 1024
Backlight Lifetime	50,000 hours
Visual Characteristics	
Colors	16.7 million
Aspect Ratio	5:4
Viewing Angle (V/H)	160° / 170°
Contrast Ratio	1000:1
Brightness	450 nits
Input Interface	
VGA	Via VGA Transmitter
DVI	N/A
HDMI	Via HDMI Transmitter
Display Port	N/A
CVBS	N/A
YPbPr	N/A
Touchscreen	
Technology	5-Wire Resistive
Interface	RS-232 Via VGA Transmitter / USB Via HDMI Transmitter
Driver	Win XP, Win 7, Win10
Enclosure	
Color	Stainless Steel
Protection	Meets NEMA 4X
Power/Thermal Specs	
Power Requirement (Max)	24VDC / 0.53A
Power Consumption (Max)	13 W
Recommended Power Supply	18 W
Heat Dissipation	43 BTU/hr
Physical Information	
Mounting	Multiple Mount Options
Net Weight	32 Lbs / 14.51 Kg
Dimension (W x H x D)	17.80 x 15.19 x 4.40 inch 452.1 x 385.8 x 111.8 mm
Recommended Cutout Dimension (WxH)	N/A
Rating	Meets NEMA 4X
Certification	UL508
Environmental	
Operating Temperature	0 to 50°C (32 to 122°F)
Storage Temperature	-20 to 60°C (-4 to 140°F)
Humidity	5% to 95% non-condensing

Dimension Drawing

Model Name: ADM-5819AX
Size Unit: inch(mm)

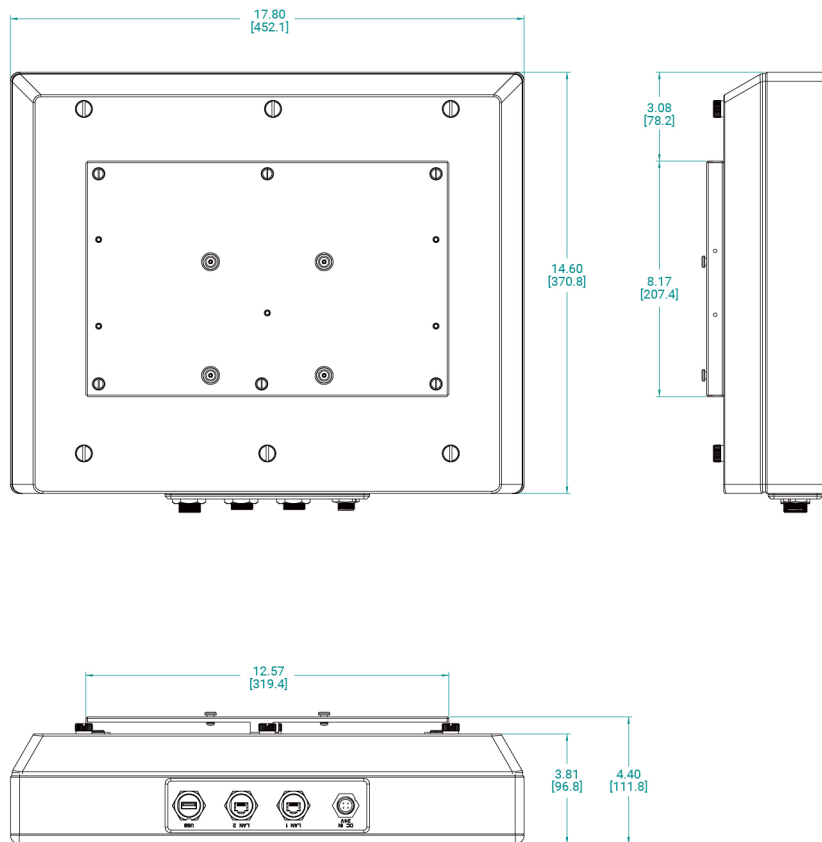

Ordering Information

Item	ADM-5819AX-00A
LCD Display	19" / 1280 x 1024
Touch Screen	5-Wire Resistive
Enclosure	Stainless Steel
Extender Video Input	HDMI via HDMI Transmitter
Power Supply	Powered by HDMI Transmitter

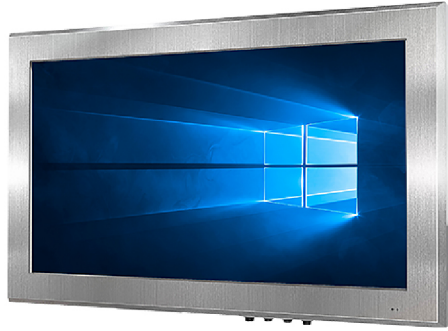

ADM-5842AX

Waterproof 42-inch KVM Extender Integrated LCD Display Monitor

Features

- 42-inch LCD Display, 1920 x 1080 resolutions
- 5-Wire Resistive Touch Screen
- Waterproof Stainless-Steel Enclosure
- Enclosure meets IP65 / NEMA 4X requirements

Integrated VGA & RS-232 Extender Option:

- Video signal transmission length up to 1,000 ft (330m) over CAT5e cable
- Adjustable equalization and gain control
- De-skew compensation available for RGB delay control
- 24VDC Input

Integrated HDMI & USB Extender Option:

- Single CAT6 cable connection to KVM Transmitter
- True one-cable solution up to 100 meters CAT6 cable
- Built-in a 2-port USB 2.0 hub to support multiple USB devices.
- Built-in a 1-port 100BaseT Ethernet pass-through
- 24VDC Input

Specifications

Model Name	ADM-5842AX
LCD Display	
Display Size	42"
Max Resolution	1920 x 1080
Backlight Lifetime	50,000 hours
Visual Characteristics	
Colors	1073 million
Aspect Ratio	16:9
Viewing Angle (V/H)	178° / 178°
Contrast Ratio	4000:1
Brightness	500 nits
Input Interface	
VGA	Via VGA Transmitter
DVI	N/A
HDMI	Via HDMI Transmitter
Display Port	N/A
CVBS	N/A
YPbPr	N/A
Touchscreen	
Technology	Infrared
Interface	RS-232 Via VGA Transmitter / USB Via HDMI Transmitter
Driver	Win XP, Win 7, Win10
Power/Thermal Specs	
Power Requirement (Max)	24VDC / 6.83A
Power Consumption (Max)	164 W
Recommended Power Supply	234 W
Heat Dissipation	559 BTU/hr
Physical Information	
Mounting	VESA Mount / Wall Mount
Net Weight	110 Lbs/ 50 kg
Dimension (W x H x D)	42.87 x 27.29 x 5.38 inch 1089.0 x 693.05 x 136.1 mm
Recommended Cutout Dimension (WxH)	N/A
Rating	Meets NEMA 4X
Certification	UL508
Environmental	
Operating Temperature	0 to 50°C (32 to 122°F)
Storage Temperature	-20 to 60°C (-4 to 140°F)
Humidity	0% to 95% non-condensing

Dimension Drawing

Model Name: ADM-5842AX

Size Unit: inch(mm)

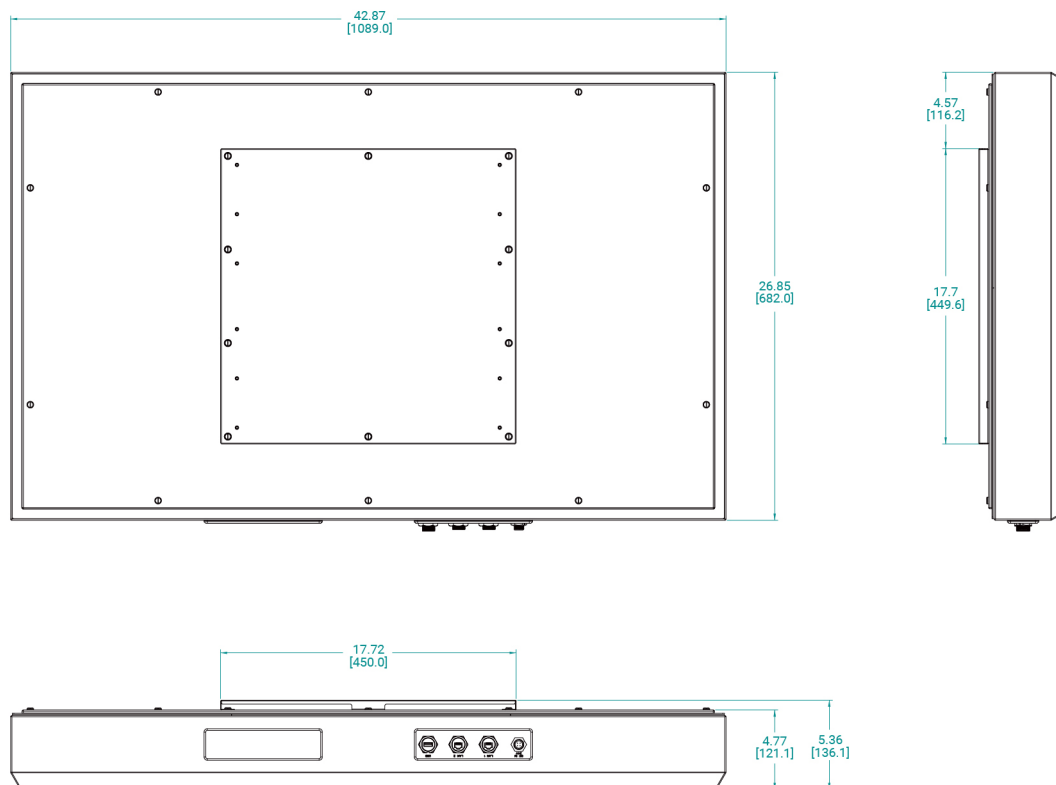

Ordering Information

Item	ADM-5842AX-004	ADM-5842AX-Z04
LCD Display	42" LCD / 1920 x 1080	42" LCD / 1920 x 1080
Touch Screen	IR	No Touch
Enclosure	Stainless Steel	Stainless Steel
Extender Video Input	VGA via VGA Transmitter	VGA via VGA Transmitter
Power Supply	24VDC	24VDC

Item	ADM-5842AX-00A	ADM-5842AX-Z0A
LCD Display	42" LCD / 1920 x 1080	42" LCD / 1920 x 1080
Touch Screen	IR	No Touch
Enclosure	Stainless Steel	Stainless Steel
Extender Video Input	HDMI via HDMI Transmitter	HDMI via HDMI Transmitter
Power Supply	24VDC	24VDC



ARISTA Corporation (USA)

 48460 Lakeview Blvd, Fremont, CA 94538

 Phone : +1-510-226-1800  eFax : 510-405-8437

 sales@goarista.com  www.aristaipc.com